



KONICA MINOLTA

# SPECTROPHOTOMETER CM-2500d

High performance, low cost  
portable spectrophotometer.



Giving Shape to Ideas

# Designed for versatility in various applications, the CM-2500d is a portable integrating sphere spectrophotometer incorporating Numerical Gloss Control.

**Simultaneous measurement of SCI (specular component included) and SCE (specular component excluded). Advanced Numerical Gloss Control.**

Simultaneous measurement of SCI and SCE displays the data on the LCD in only 1.5 seconds. Unlike conventional spectrophotometers, there is no need to mechanically switch between SCI and SCE mode. This improves working efficiency and provides stable measured data since the measurement area does not shift when the mode is switched. And also Relativity Gloss Value can be displayed by using Numerical Gloss Control.



For plastics, paints, resins and consumer products

**High reliability and long life. Maintenance-free design.**

The number of moving parts in the instrument is minimized through the introduction of numerical control technology. The CM-2500d can be used with confidence, since it has been developed, manufactured and calibrated to meet ISO 9001 requirements.

**Allows measurement in any position. Compact, lightweight, with an easy-to-operate navigation wheel and large LCD display.**

The battery-powered small, light body allows the instrument to be placed in any position at the sample surface. The CM-2500d's large LCD display and its reverse display function provide easy reading, irrespective of which hand it is held in. Using your finger, the navigation wheel allows simple, user friendly operation.

( Turn ) ( Push )



For paints, plastics, automobiles, ceramics, architectural interiors, textile, paper, food etc.

**Promotes accurate, consistent color communication. Conforms to widely-accepted industry standards and allows measurements in all popular color spaces.**

The optics use an integrating sphere to provide diffuse illumination/8-degree viewing system.

The CM-2500d conforms to all widely accepted standards including ISO, JIS, DIN, CIE and ASTM, and generates measurements in color notations such as L\*a\*b\*, Yxy, Munsell and CIE2000.

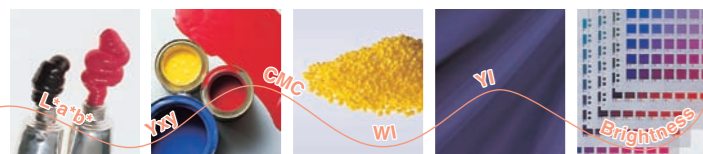

In various applications

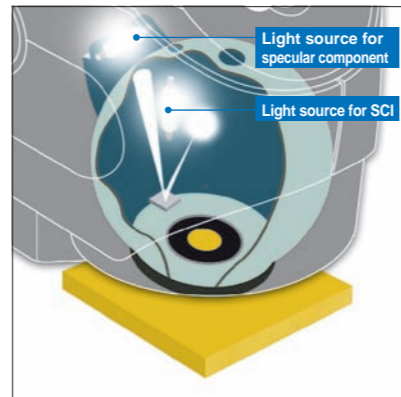

The LCD specifications are subject to change without prior notice.

• SCI is a method in which measurements are taken with the specular reflection included. For this reason, it minimizes influences of the surface condition of a sample, and is especially suitable for color quality control and Computer Color Matching.

• SCE is a method in which measurements are taken excluding the specular reflection. This type of measurement provides results similar to those observed visually.

**Expanded LCD display (64 x 240 dots) Displays large quantities of information (simultaneous display of SCI and SCE data etc.)**

**High-accuracy sensor Measures at 10nm intervals for the full wavelength range. Excellent repeatability**

**Illuminated viewfinder**

**Easy-to-carry, compact and light body 670g (without batteries)**

**Numerical Gloss Control**

**Light source for specular component**

**Light source for SCI**

**Measures the target with high accuracy. Easy-to-carry stylish body with an illuminated viewfinder.**

The user can choose the most suitable measurement area for the target. The easy-to-carry body with the illuminated viewfinder enables the user to position the instrument on the target quickly and accurately.



For pharmaceuticals, cosmetics, printing, building materials, textiles, food etc.

**d:8 integrating sphere optics that conform to industry standards**

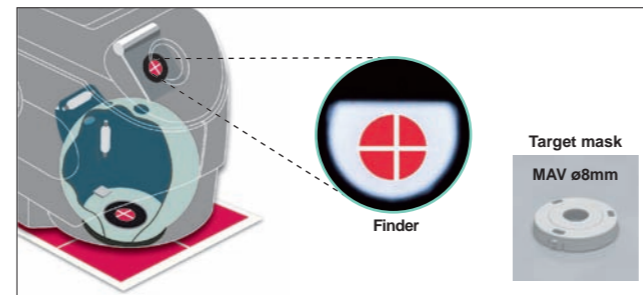

## Powerful partnership between CM-2500d and SpectraMagic™ NX

Color Data Software

**SpectraMagic™ NX (Optional)**

Supports Windows®XP/Vista/7

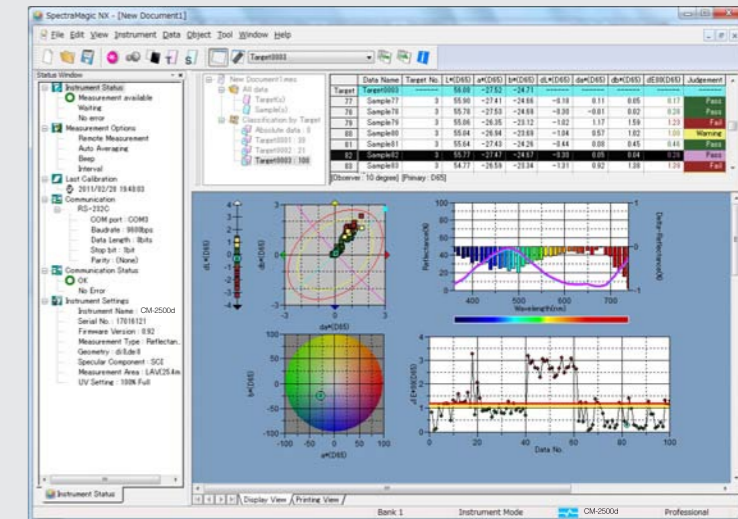

SpectraMagic™ NX enables you to perform comprehensive color inspection and analysis of incoming raw materials, in process production, and outbound color critical goods and materials in virtually any industry. With SpectraMagic™ NX you can insert digital images with measured data. Measure samples in any of 8 universally accepted color spaces. Select from 16 illuminants, and up to 40 indices to determine specific color and appearance properties, such as strength, brightness, haze, yellowness, opacity and strength. You can even configure up to 8 customized color equations. Reports range from simple Pass/Fail to trend charts, histograms, color plots, and spectral graphs. SpectraMagic™ NX comes with predefined templates using skin technology, or you can create your own templates. For illustrations and explanations to understanding color and color measurement technology, there is a link to Konica Minolta's well known and respected "Precise Color Communication". Step by step navigation help.

• Windows® is a trademark of Microsoft Corporation in the USA and other countries.

Specifications	
<b>Illumination/viewing system</b>	di:8°, de:8° (diffuse illumination, 8-degree viewing), equipped with simultaneous measurement of SCI (specular component included) /SCE (specular component excluded) Conforms to CIE No.15,ISO 7724/1, ASTM E1164, DIN 5033 Teil7 and JIS Z8722 Condition C standard.
<b>Sphere Size</b>	ø52mm
<b>Light-receiving element</b>	Silicon photodiode array (dual 40 elements)
<b>Spectral separation device</b>	Diffraction grating
<b>Wavelength range</b>	360nm to 740nm
<b>Wavelength pitch</b>	10nm
<b>Half bandwidth</b>	Approx. 10nm
<b>Reflectance range</b>	0 to 175%, resolution: 0.01%
<b>Light source</b>	2 pulsed xenon lamps
<b>Measurement time</b>	Approx. 1.5 seconds (approx. 2 seconds for fluorescent measurement)
<b>Minimum interval between measurements</b>	3 seconds for SCI/SCE (4 seconds for fluorescent measurement)
<b>Battery performance</b>	Alkaline manganese: approx. 1000 measurements
<b>Measurement/illumination area</b>	MAV: ø8mm/ø11mm
<b>Repeatability</b>	Spectral Reflectance: Standard deviation within 0.1% (360 to 380nm within 0.2%) Colorimetric Value: Standard deviation within ΔE*ab 0.04 (Measurement conditions: White calibration plate measured 30 times at 10-second intervals after white calibration was performed)
<b>Inter instrument agreement</b>	within ΔE*ab 0.2 (MAV/SCI) Average for 12BCRA Series II color tiles compared to values measured with master body.
<b>Measurement mode</b>	Single measurement/automatic averaging of multiple measurements (auto mode: 3, 5, 8 times/manual mode)
<b>Interface</b>	RS-232C standard
<b>Observer</b>	2/10 degrees (CIE 1931/2°, CIE 1964/10°)
<b>Illuminant</b>	A, C, D50, D65, F2, F6, F7, F8, F10, F11, F12 (simultaneous evaluation is possible using two light sources)
<b>Display data</b>	Spectral value/graph, colorimetric value, color difference value/graph, PASS/FAIL result
<b>Color space/colorimetric data</b>	L*a*b*, L*C*h, CMC (1:1), CMC (2:1), CIE94, Hunter Lab, Yxy, Munsell, XYZ, MI, WI (ASTM E313), YI (ASTM E313/ASTM D1925), ISO Brightness (ISO 2470), Density status A/T, WI/Tint (CIE), CIE00
<b>Data memory</b>	1700 pieces of data (as SCI/SCE 1 data) * 700 pieces of data in the "defined in COND." mode. * Total of the sample data for the COND and TASK modes and color difference target data
<b>Tolerance Display</b>	Tolerance for color difference (both box and elliptical tolerances can be set)
<b>Power source</b>	4 AA-size battery or AC adapter
<b>Size (WxHxD)</b>	69 x 96 x 193mm
<b>Weight</b>	Approx. 670g (without batteries)
<b>Operating temperature/humidity range (*1)</b>	5 to 40°C, relative humidity 80% or less (at 35°C) with no condensation
<b>Storage temperature/humidity range</b>	0 to 45°C, relative humidity 80% or less (at 35°C) with no condensation
<b>Standard accessories</b>	White calibration plate, Target mask ø8mm, RS-232C cable, AC adapter, AA-size battery (x4)
<b>Optional Accessories</b>	Hard case, Dust cover set, Dust cover, SpectraMagic™NX (software), Zero calibration box

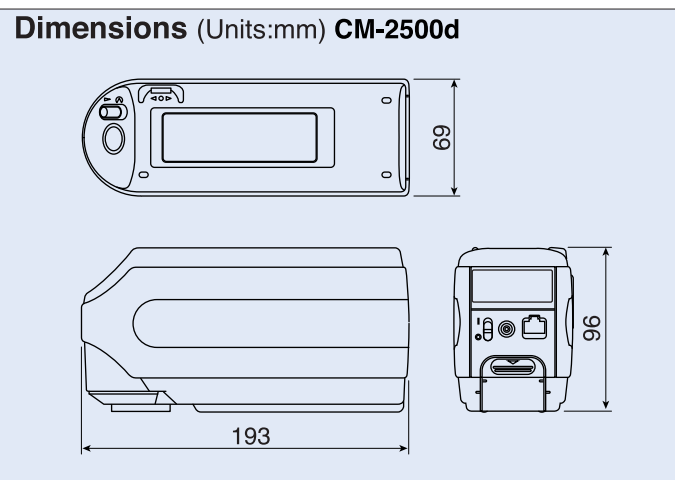
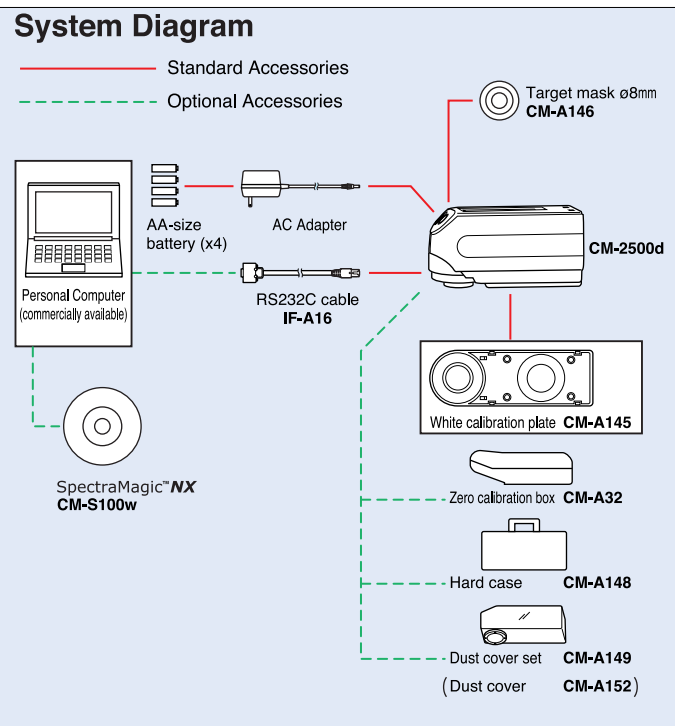

\*1 Operating temperature/humidity range of products for North America: 5 to 40°C, relative humidity 80% or less (at 31°C) with no condensation

### Color control network by spectrophotometer

High inter-instrument agreement between the portable CM-2500d spectrophotometer and the desktop CM-3000 series make it easy to build a total color control network.

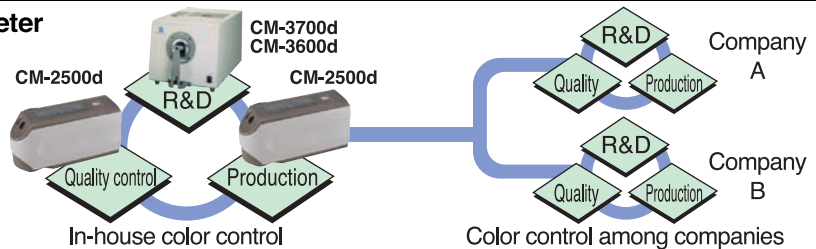

### SAFETY PRECAUTIONS

For correct use and for your safety, be sure to read the instruction manual before using the instrument.



- Always connect the instrument to the specified power supply voltage. Improper connection may cause a fire or electric shock.
- Be sure to use the specified batteries. Using improper batteries may cause a fire or electric shock.



Certificate No.: L RQ 0960094/A  
Registration Date: March 3, 1995



Certificate No.: JQA-E-80027  
Registration Date: March 12, 1997

\* The specifications and drawings given here are subject to change without prior notice.

**KONICA MINOLTA OPTICS, INC.**  
Konica Minolta Sensing Americas, Inc  
Konica Minolta Sensing Europe B.V.

Osaka, Japan  
New Jersey, U.S.A.  
European Headquarter /BENELUX  
German Office  
French Office  
UK Office  
Italian Office  
Swiss Office  
Nordic Office  
Polish Office  
SE Sales Division  
Beijing Branch  
Guangzhou Branch  
Chongqing Office  
Qingdao Office  
Wuhan Office

**Phone** : 888-473-2656 (in USA), 201-236-4300 (outside USA)  
Nieuwegein, Netherlands  
München, Germany  
Roissy CDG, France  
Warrington, United Kingdom  
Milan, Italy  
Dietikon, Switzerland  
Västra Frölunda, Sweden  
Wrocław, Poland  
Shanghai, China  
Beijing, China  
Guangdong, China  
Chongqing, China  
Shandong, China  
Hubei, China  
Singapore  
Seoul, Korea  
Bangkok, Thailand

**Fax** : 201-785-2482  
+31(0)30 248-1280  
+49(0)89 4357 156 99  
+33(0)1 80 11 10 82  
+44(0)1925 711143  
+39 02 39011.223  
+41(0)43 322-9809  
+46(0)31 474945  
+48(0)71 734 52 10  
+86-(0)21-5489 0202  
+86-(0)10-8522 1551  
+86-(0)20-3826 4220  
+86-(0)23-6773 4988  
+86-(0)532-8079 1871  
+86-(0)27-8544 9942  
+65 6563-5533  
+82(0)2-523-9726  
+662 361-3730 to 7

**Konica Minolta (CHINA) Investment Ltd.**  
Beijing Branch  
Guangzhou Branch  
Chongqing Office  
Qingdao Office  
Wuhan Office

**Konica Minolta Sensing Singapore Pte Ltd.**  
**KONICA MINOLTA OPTICS, INC.**  
Seoul Office  
Thailand Representative Office

Addresses and telephone/fax numbers are subject to change without notice. For the latest contact information, please refer to the KONICA MINOLTA OPTICS Worldwide Offices web page :

<http://konicaminolta.com/instruments/about/network>