



KONICA MINOLTA

SPECTROPHOTOMETER CM-3630A

State-of-the art ISO-Standard
compliant measuring device for
the pulp & paper industry with
unrivalled precision and stability
in whiteness measurement



Spectrophotometer CM-3630A

Compatibility with the former CM-3630

The long-time standard model in the paper manufacturing industry, the CM-3630, has been rethought anew and its functionality enhanced - this means that all users of the old CM-3630 can use their historical measurement data without transition problems.

Improved functionality

1. Improved targeting by camera preview

Easy positioning in real time to target small samples with patterns or inhomogeneous surfaces.

*Requires separate software connection

2. Smaller measurement area possible

For your convenience, we added smaller apertures to analyze small-sized samples or printed samples with patterns; for the first time you can reliably compare data for smaller targets.

3. Windows tablet ready for standalone usage

Using the USB interface and side-fixtures, the CM3630A can be used together with the PaperManager Software to create a touchscreen-ready, standalone system with minimum footprint.

Optional accessories

To offer you a convenient workflow, additional jigs are available, to e.g. measure opacity or larger sheet material

* The listed functions are available on the instrument for use by software. However, whether or not the functions are included in the software depends on the software being used.



Highly competitive markets, such as the paper, pulp and cellulose industry, require a commitment to top quality throughout. With Konica Minolta's state-of-the-art Spectrophotometer CM-3630A and the dedicated Paper-production control software PaperManager you can precisely monitor production at all times. Designed to keep an eye on the optical properties of pulp and paper during the complete production process, the ISO compliant CM-3630A measures brightness, opacity, fluorescence, color, whiteness and tint. To meet your needs, the touch-pad enabled PaperManager software has been developed in close cooperation with the paper, pulp and cellulose industry and will also run on tablet PCs for "standalone" usage.

Spectrophotometer
CM-3630A

PaperManager
software

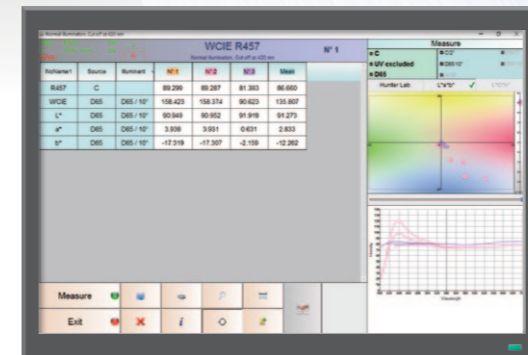

Tablet computer can be attached using a bracket.

* Tablet computer and bracket are not included.
* External Tablet computer holder setup for illustration only. Real setup might vary with holder and tablet used.

PaperManager software

Dedicated Software for production control in the Pulp-&Paper-Industry

Minimum Operation Workflow ...

PaperManager requires a minimum of operations and thus allows fast quality assessment of any industry related parameters such as CIELAB, Whiteness, Brightness, Fluorescence, Tint, Opacity and many more. No more confusion by mixing production control and general QC tests as in conventional multi-purpose software. PaperManager is all you need to control your production line. Workflows and measurement parameters can be setup by the supervisor for quick selection by the operator.

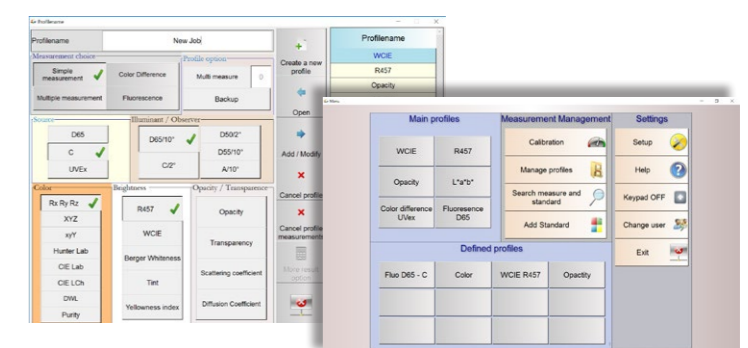

...with Maximum convenience and flexibility...

Using the predefined setups made by an administrator, every operator gets valuable assistance in performing the most commonly used measurement routines without the need to set them up each time - the result is overall increased productivity with fewer error sources. For easy production usage, PaperManager supports Touchscreen usage and user profile setups as well as remote support using embedded TeamViewer Software. Measured data can be stored in the connected database and exported either as standard export formats (e.g. xls) or as definable data export via XML to third party systems.

...for Reliable Whiteness Measurements.

To get correct measurement readings of paper with Optical Brightening Agents, the amount of UV radiation must be controlled and adjusted. PaperManager offers several methods to adjust the UV radiation using the patented Numerical UV Control (NUVC) of the CM-3630A and makes calibration and adjustments to whiteness and tint an unrivaled swift and quick procedure.

Specifications

CM-3630A	
Illumination/viewing system	Reflectance d: 0° (diffused illumination, 0-degree viewing)
Integrating sphere	ø 152 mm (6 inch)
Detector	Silicon photodiode array (dual 40 elements)
Spectral separation device	Diffraction grating
Wavelength range	360 nm – 740 nm
Wavelength pitch	10 nm
Half bandwidth	Approx. 10 nm
Reflectance range	0 to 200%; Display resolution: 0.01%
Light source	Pulsed xenon lamp ×3
Illumination area	LAV : ø 34 mm; MAV : ø 11 mm
Measurement area	LAV : ø 30 mm; MAV : ø 8 mm
Measurement time	Within 1.5 sec
Minimum measurement interval	Within 2 sec (UV 100% measurement) Within 3 sec (UV 0%/UV adjusted measurement)
Repeatability	Colorimetric values : Standard deviation within ΔE^*ab 0.02 (White Calibration Plate) Spectral reflectance : Standard deviation within 0.1% (hen a white calibration plate is measured 30 times at 10-second intervals after white calibration)
Inter-instrument agreement	Within ΔE^*ab 0.2 (Based on average for 12 BCRA Series II color tiles; compared to values measured with a master body under Konica Minolta standard measurement conditions)
UV setting	100% / 0% / Adjusted (Instantaneous numerical adjustment of UV with no mechanical filter movement required); 400 nm and 420 nm UV cutoff filters
Applicable standards	LAV measurements conform to ISO 2469, JIS P8148, DIN 53145-1 and DIN 53145-2 standards.
Viewfinder function	Using built-in camera; Software (not included) required.
Interface	USB2.0 Full speed
Power	Dedicated AC adapter
Operating temperature/humidity range	Temperature: 13 to 33°C, Relative humidity: 80% or less (at 33°C) with no condensation
Storage Temperature/humidity rang	Temperature: 0 to 40°C, Relative humidity: 80% or less (at 35°C) with no condensation
Size (W×H×D)	Approx. 300 ×612 ×315 mm
Weight	Approx. 16 kg

System Diagram

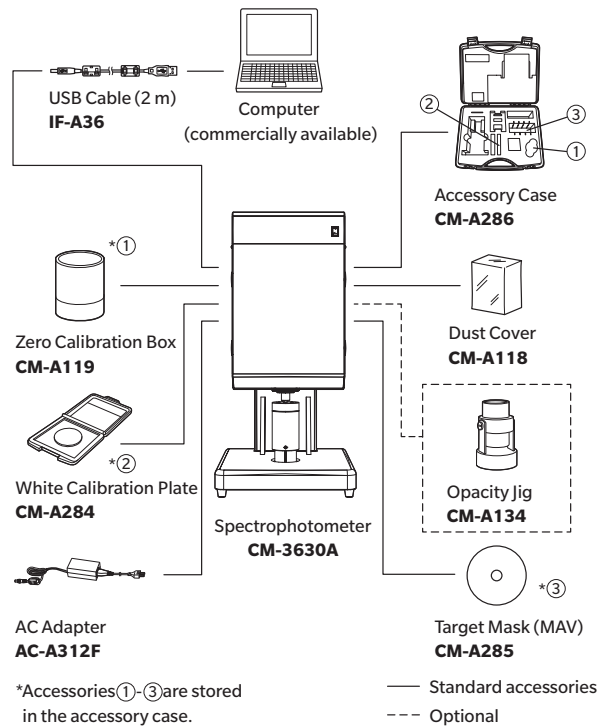

Dimensions

(Unit: mm)

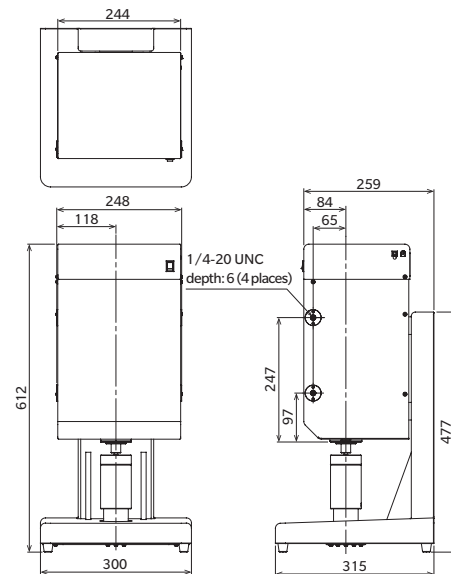

SAFETY PRECAUTIONS

For correct use and for your safety, be sure to read the instruction manual before using the instrument.

- Be sure to use the specified power supply voltage. Improper connection may cause a fire or electric shock.

ISO Certifications of KONICA MINOLTA, Inc., Sakai Site



JQA-QMA1588
Design, development, manufacture/
manufacturing management, calibration, and
service of measuring instruments



JQA-E-80027
Design, development, manufacture, service and sales
of measuring instruments

KONICA MINOLTA, INC.	Osaka, Japan			
Konica Minolta Sensing Americas, Inc.	New Jersey, U.S.A.	PHONE: (888)473-2656 (in USA), +1(201)236-4300 (outside USA)	FAX: +1(201)785-2480	E-Mail: service.us@konicaminolta.com
Konica Minolta Sensing Europe B.V.	European HQ / BENELUX German Office French Office UK Office Italian Office Swiss Office Nordic Office Polish Office Turkish Office	Nieuwegein, Netherlands München, Germany Roissy CDG Cedex, France Warrington, United Kingdom Cinisello Balsamo, Italy Dietikon, Switzerland VÄSTRA FRÖLUNDA, Sweden Wrocław, Poland İstanbul, Turkey	PHONE: +31(0)30 248-1193 PHONE: +49(0)89 4357 156 0 PHONE: +33(0)1 80 11 10 70 PHONE: +44(0)1925 467300 PHONE: +39 02849488.00 PHONE: +41(0)43 322-9800 PHONE: +46(0)31 7059464 PHONE: +48(0)71 73452-11 PHONE: +90(0)216-528 56 56	E-Mail: info.benelux@seu.konicaminolta.eu E-Mail: info.germany@seu.konicaminolta.eu E-Mail: info.france@seu.konicaminolta.eu E-Mail: info.uk@seu.konicaminolta.eu E-Mail: info.italy@seu.konicaminolta.eu E-Mail: info.switzerland@seu.konicaminolta.eu E-Mail: info.nordic@seu.konicaminolta.eu E-Mail: info.poland@seu.konicaminolta.eu E-Mail: info.sensing@konicaminolta.com.tr
Konica Minolta (CHINA) Investment Ltd.	SE Sales Division Beijing Office Guangzhou Office Chongqing Office Qingdao Office Wuhan Office Shenzhen Office	Shanghai, China Beijing, China Guangzhou, China Chongqing, China Shandong, China Hubei, China Shenzhen, China	PHONE: +86-(0)21-6057-1089 PHONE: +86-(0)10-8522 1551 PHONE: +86-(0)20-3826 4220 PHONE: +86-(0)23-6773 4988 PHONE: +86-(0)532-8079 1871 PHONE: +86-(0)27-8544 9942 PHONE: +86-(0)755-2868 7535	E-Mail: hcn_sensing@gcp.konicaminolta.com E-Mail: hcn_sensing@gcp.konicaminolta.com E-Mail: hcn_sensing@gcp.konicaminolta.com E-Mail: hcn_sensing@gcp.konicaminolta.com E-Mail: hcn_sensing@gcp.konicaminolta.com E-Mail: hcn_sensing@gcp.konicaminolta.com E-Mail: hcn_sensing@gcp.konicaminolta.com
Konica Minolta Sensing Singapore Pte. Ltd.	Singapore		PHONE: +65 6563-5533	E-Mail: se-service.sg@konicaminolta.com
Konica Minolta Sensing Korea Co., Ltd.	Korean HQ / Kintex Cheonan Office	Goyang-si, Korea Cheonan-si, Korea	PHONE: +82(0)2-523-9726 PHONE: +82(0)41-556-9726	FAX: +82(0)31-995-6511

Addresses and telephone/fax numbers and e-mail address are subject to change without notice. For the latest contact information, please refer to KONICA MINOLTA Worldwide Offices web page:

<https://konicaminolta.com/instruments/network>