

Handling of Rotating Stage (Rotating Stage Kit 60YAW-602R)

The rotating stage kit is designed to rotate the object at certain angles accurately and facilitate scan operation and integration of the scanned images.





⚠ WARNING

The rotating stage kit must be operated correctly and safely according to this manual and those supplied with the components. Failure to do so may result in unexpected accidents and trouble such as fire and electric shocks.

Before using the rotating stage kit connected with the host computer, read the instruction manuals of the rotating stage kit, measuring machines (VIVID Series and RANGE7) and host computer.

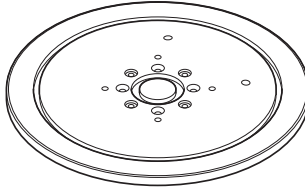
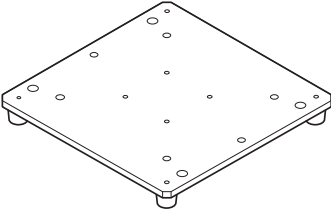
1. Components Required Assembling the Rotating Stage

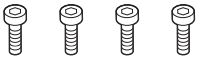
(1) The rotating stage kit 60YAW-602R includes the following components.

Rotating Stage Kit 60YAW-602R		
Rotating Table 1	Base 1	Calibration Chart S, L 1 of each
		Calibration Chart S Calibration Chart L  
Hexagon Bolt 4 (For mounting on the rotating table)	Hexagon Bolt 3 (For mounting on the base)	Hexagon Wrench (M4) 1
		

(2) Others

The following devices are required in addition to the rotating stage kit.

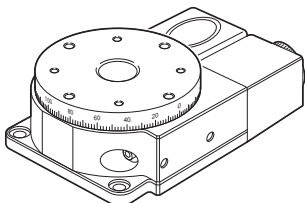
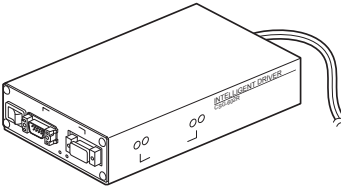
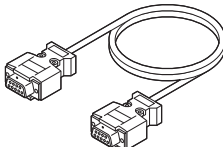
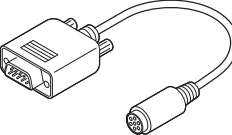
Rotating Stage 1	Control Box 1 SHOT-602	RS-232C Cable 1	Motor Connecting Cable 1
			

2. Mounting on the Base

To stabilize the rotating stage, it must be mounted on the base.

Note The rotating stage must be mounted on the base before mounting the rotating table on it.
When using the frame set, pay attention to the mounting position and direction of the rotating stage to prevent its driving section from affecting scan operation using the measuring machine.

Mounting Method

1 Place the rotating stage on the base. Make sure to align the mounting holes on the base with those on the rotating stage.

Note Pay attention to the rotating stage position against the positioning holes on the base as illustrated.

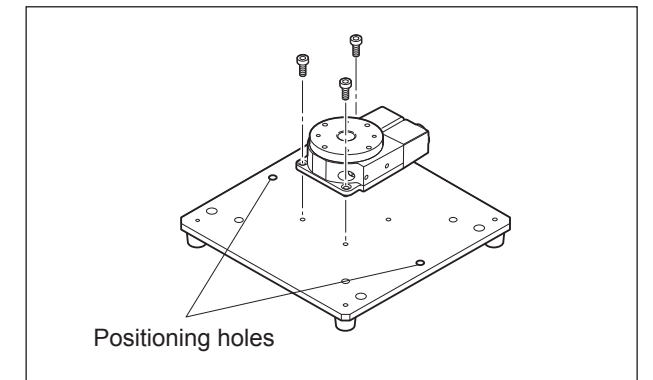

2 Tighten the three hexagon bolts using the hexagon wrench supplied with the product. The procedure is now complete.

3. Mounting the Rotating Table

The rotating table is designed to ensure that an object can be placed on the rotating stage securely. When using a calibration chart, always mount the rotating table.

Note Before mounting the rotating table, the rotating stage must be mounted on the base.
When using the frame set, mount the rotating table so that the calibration chart positioning holes on the rotating table, which is in the home position, should face the front of the measuring machine.

Mounting Method

1 Place the rotating table on the rotating stage. Make sure to align the mounting holes on the rotating table with those on the rotating stage.

Note Pay attention to the rotating stage's home position and rotating table's mounting direction.

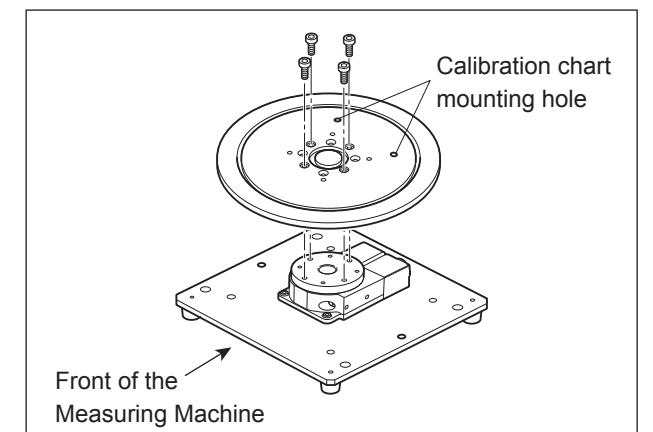

2 Tighten the four hexagon bolts using the hexagon wrench supplied with the product. The procedure is now complete.

4. Connecting the Rotating Stage to the Computer

To operate the rotating stage from the computer using 3D data processing software (ex. KONICA MINOLTA RANGE VIEWER, Polygon Editing Tool), connect the rotating stage to the computer as described below.

Ref. For the operating method of the rotating stage using 3D data processing software (ex. KONICA MINOLTA RANGE VIEWER, Polygon Editing Tool), refer to each software instruction manual.

Connecting Method

- 1 Turn OFF the power switch of both the computer and control box.

Note If the rotating stage is connected to a computer with power turned ON, damage to the computer or rotating stage may result. Before connecting them, always make sure to turn OFF the power.

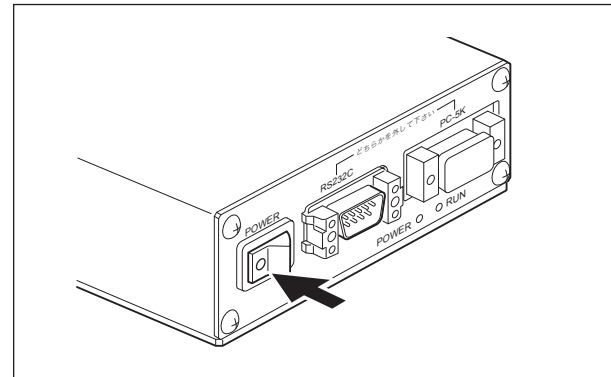

- 2 Connect the female plug of the motor connecting cable to the rotating stage.

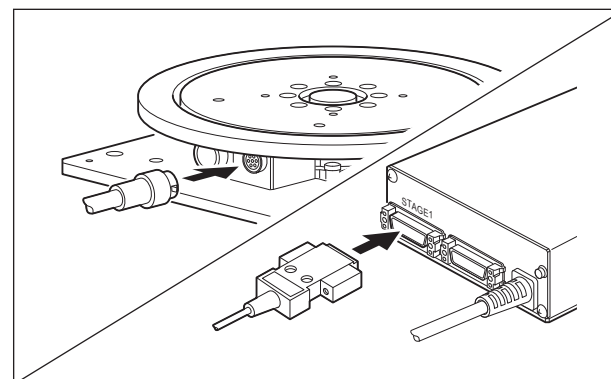

- 3 Connect the male plug of the motor connecting cable to the "STAGE 1" terminal of the control box.

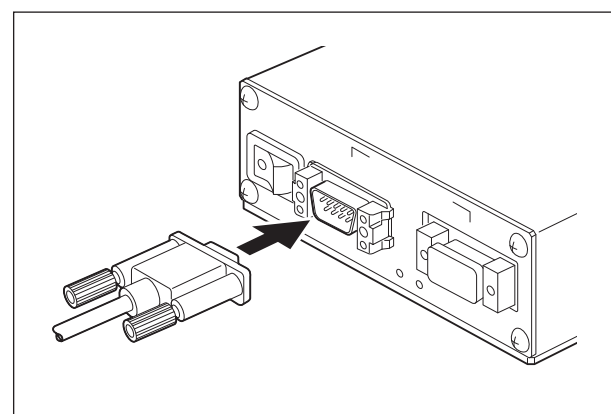

- 4 Plug one end of the RS-232C cable to the control box.

- 5 Plug the other end of the RS-232C cable to the serial port (COM port) on the computer. The procedure is now complete.

5. Setting the Control Box Current

Turn the current adjusting VR to set the current flowing when the rotating stage motor drives and stops.



CAUTION



Make sure that the current adjusting VR is set correctly. If not, the motor may burn or may not rotate properly due to insufficient torque.

Memo For a detailed explanation of the adjusting method, refer to the instruction manual of the control box.

Setting Method

- 1 Turn the current adjusting VR using a flat-blade screwdriver to set it to the following positions.

Setting Values
ORUN: 7 OSTOP: 3

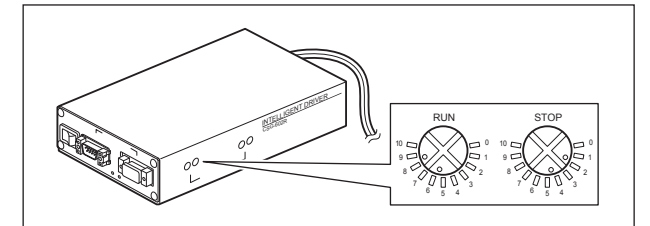

6. Mounting the Calibration Chart

The calibration chart is designed to check the position of the rotation axis of the object placed on the rotating stage and scanned. It is an indispensable component to create 3D data (distance from the rotating stage's rotation axis to the measuring machine, registration of scan images).

Memo Normally, the calibration chart S must be used. If it is not possible to perform calibration using calibration chart S, for instance, because of excessive distance to the object, use the calibration chart L.

Note When the calibration chart gets dirty, wipe it with a clean, soft, dry cloth. Never use solvents like thinner and benzene.

Mounting Method

- 1 Mount the rotating table on the rotating stage.

- 2 Direct the black-lined edge of the calibration chart S to the measuring machine, and place the chart on the rotating table. Make sure to align the two positioning pins on the calibration chart S with the two mounting holes on the rotating table.

Memo

If it is not possible to perform calibration using the calibration chart S, mount the calibration chart L on the rotating table, and perform calibration again

- 3 The procedure is now complete.

When calibration is not possible with the calibration chart S

Direct the black-lined edge of the calibration chart L to the measuring machine, and place the chart on the rotating table. Make sure to align the three positioning pins on the calibration chart L with the slots on the rotating table.

Memo

When using the calibration chart L, make sure that its black-lined edge faces approximately direct to the front of the measuring machine.

